

**INTERNATIONAL JOURNAL OF ENGINEERING SCIENCES & RESEARCH  
TECHNOLOGY****STRUCTURE AND THERMAL ANALYSIS OF INTEGRAL SHAFT BEARING  
USING ANSYSBENCHWORKS 14.0****Vimal Kumar Pal<sup>\*1</sup> & Dr. Prabhat Kumar Sinha<sup>2</sup>**<sup>\*1</sup>M.Tech. Scholar, Dept. of Mechanical Engineering, SHUATS, Allahabad, U.P., India<sup>2</sup>Assistant Professor, Dept. of Mechanical Engineering, SHUATS Allahabad, U.P., India

DOI: 10.5281/zenodo.834598

**ABSTRACT**

An integral shaft bearing is popular for carrying higher specific load capacity, preventing misalignment defects and eliminating the risk of undesirable distortion of bearings, in comparison to any other bearings. Integral shaft bearing are used to reduced rotational friction and support, axial and radial loads which generate friction and increased temperature and stresses inside the bearings. If the generated heat cannot be properly removed from the inside bearing ,the temperature might exceed certain limit. Due to which the bearing should be fail. That why I analyze heat flow, temperature distribution and stress in a bearing system, a typical integral shaft bearing and its environment has been design and analyze the system using the famous finite elements tool ANSYS workbench 14.0. In this research, structural and thermal characteristics performance of integral shaft bearing to Analyze stress, thermal elongation and temperature distribution due to friction also its effect on bearing clearances , and vice-versa, has been investigated on different materials with different parameters.

**KEYWORDS:** Integral shaft bearing, Modeling , Meshing Structural & Thermal Module.**I. INTRODUCTION**

A bearing is a machine element that constrains relative motion to only the desired motion, and reduces friction between moving parts. The design of the bearing may, for example, provide for free linear movement of the moving part or for free rotation around a fixed axis or, it may prevent a motion by controlling the vectors of normal forces that bear on the moving parts. Most bearings facilitate the desired motion by minimizing friction. bearings hold rotating components such as shafts or axles within mechanical systems, and transfer axial and radial loads from the source of the load to the structure supporting it. The term "bearing" is derived from the verb "to bear"; a bearing being a machine element that allows one part to bear (i.e., to support) another. The simplest bearings are bearing surfaces, cut or formed into a part, with varying degrees of control over the form, size, roughness and location of the surface. Other bearings are separate devices installed into a machine or machine part. The most sophisticated bearings for the most demanding applications are very precise devices; their manufacture requires some of the highest standards of current technology

A bearing is a machine element that constrains relative motion to only the desired motion, and reduces friction between moving parts. The design of the bearing may, for example, provide for free linear movement of the moving part or for free rotation around a fixed axis or, it may prevent a motion by controlling the vectors of normal forces that bear on the moving parts. Most bearings facilitate the desired motion by minimizing friction. bearings hold rotating components such as shafts or axles within mechanical systems, and transfer axial and radial loads from the source of the load to the structure supporting it.

The invention of the rolling bearing, in the form of wooden rollers supporting, or bearing, an object being moved is of great antiquity, and may predate the invention of the wheel.

Though it is often claimed that the Egyptians used roller bearings in the form of tree trunks under sleds, this is modern speculation. They are depicted in their own drawings in the tomb of Djehutihotep as moving massive stone blocks on sledges with liquid-lubricated runners which would constitute a plain bearing. There are also Egyptian drawings of bearings used with hand drills.

The earliest recovered example of a rolling element bearing is a wooden ball bearing supporting a rotating table from the remains of the Roman Nemi ships in Lake Nemi, Italy. The wrecks were dated to 40 BC.

Leonardo da Vinci incorporated drawings of ball bearings in his design for a helicopter around the year 1500. This is the first recorded use of bearings in an aerospace design. However, Agostino Ramelli is the first to have published sketches of roller and thrust bearings. An issue with ball and roller bearings is that the balls or rollers rub against each other causing additional friction which can be reduced by enclosing the balls or rollers within a cage. The captured, or caged, ball bearing was originally described by Galileo in the 17th century'

The first practical caged-roller bearing was invented in the mid-1740s by horologist John Harrison for his H3 marine timekeeper. This uses the bearing for a very limited oscillating motion but Harrison also used a similar bearing in a truly rotary application in a contemporaneous regulator clock.

The term "rolling bearing" includes all forms of roller and ball bearing which permit rotary motion of a shaft. Normally a whole unit of bearing is sold in the market, which includes inner ring, outer ring, rolling element (ball and roller) and the cage which separates the rolling element from each other. Rolling bearings are high precision low cost but commonly used in all kinds of rotary machine. It takes long time for the human being to develop the bearing from the initial idea to the modern rolling bearing. The reason why bearing is used is that first it can transfer moment or force. Secondly and maybe more important is that it can be interchanged easily and conveniently when it's broken. In the mechanical system, it is also possible to amount the shaft directly with housing. However, when this mechanism has some problem, the only possibility to recover the function of this system is to replace the housing or the shaft. From the mechanical engineer point of view, both of them are not only very expensive but also time consuming to manufacture a new housing or shaft with the same parameters. However when the bearings are used between them, the situation will be different. Normally there is no relative motion between shaft and inner ring or the outer ring with housing. so it has less possibility for the shaft or housing to be worn out. Usually the bearing first cracks and then the shaft or housing is broken. If the above situation happens it is really easy to it out. Just buy a new bearing from the market with the same parameter and replace it.

## II. OBJECTIVE OF PROJECT

- To design of integral shaft Bearing for water pump
- Modeling & Assembly of bearing component from 2D to 3D Model
- Stress analysis and temperature distribution for integral shaft bearing
- Thermal elongation of component in Integral Shaft Bearing at different temperature & its effect on bearing clearances

## III. FEA ANALYSIS

### Geometric Model

Integral shaft bearing product details as shown in table 3.1 as per Industrial requirements figure 3.1 shows the complete assembly of integral shaft bearing.

Bearing type	Integral shaft bearing
Type of rolling elements	Roller/ Ball
No. of rolling elements	15
Components details of assembly	Shaft, ball cage, roller cage, rollers, balls, Sleeve
Sleeve diameter	30 mm
Ball diameter	15.918 mm
Shaft diameter	6.35 mm

Part geometry of complete Bearing created in CAD environment of CATIA v5 is successfully imported to ANSYS environment.

### Stress Analysis

Finite element method is a numerical methods for solving a differential or integral Equation. It has been applied to a number of physical problems, where the governing differential equations are available . The method essentially consists of assuming the piecewise continuous function for the solution and obtaining the parameters of the function in a manner that reduces the error in the solutions. Here we have to find maximum stresses in each component of bearing, and to safe design of components material maximum stress should be less than allowable stress design allowable stress  $\sigma_{all} = \text{yield strength or ultimate strength} \times \text{factor of safety}$  . Assume factor of safety is 1, Allowable stress of material used in assembly is calculated in following table 3.2

Material Allowable Stress Table 3.2

Material	Components	Modulus of elasticity (GPa)	Yield Strength(Mpa)	Ultimate Strength(Mpa)	Allowable Stress (Mpa)
100Cr6	Shafts, Balls, Rollers, Sleeve	210	260	460	460
Nylon 101	Ball & Roller cage	36	80	NA	80
1060Aluminum Alloy	Housing	71	280	310	310

### Finite Element Analysis Of Integral Shaft Bearings

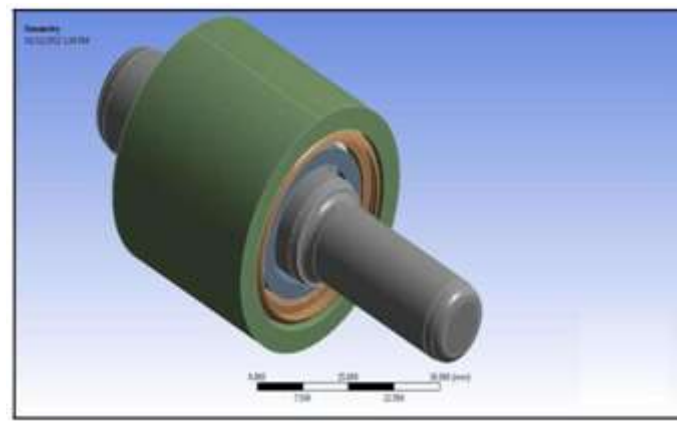
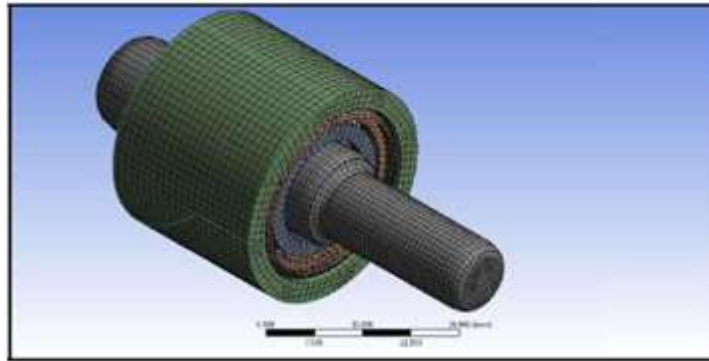

Fig.3 Integral Shaft Bearing

### Mesh Generation:

In this analysis mesh generation is auto mesh generation with element size is 20. This element size is used for all the body of Integral Shaft Bearing. Hex-dominant method is used for all the parts of Integral Shaft Bearing



Mesh Generation of whole Assembly Fig. 3.3

**Loading And Boundary Conditions:**

Loading and boundary conditions basically consist of two steps first is support and second is applying loads. Following Figure Shows the Supports and Forces.

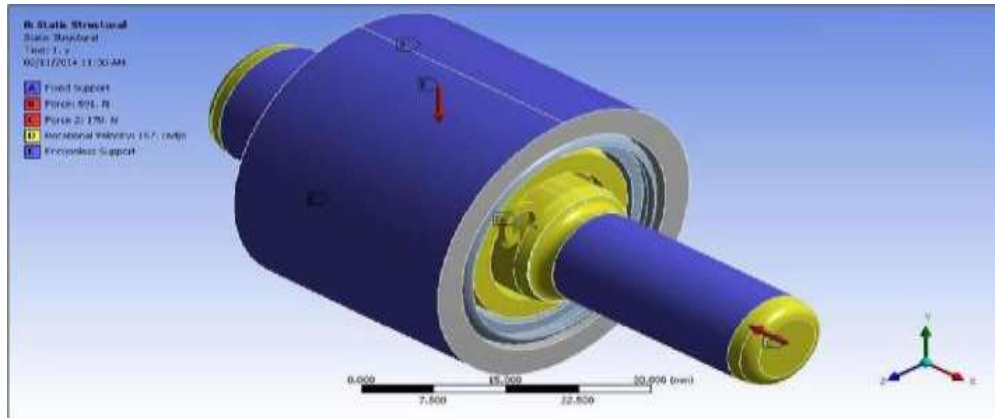

Fig3.4 Loading & Boundary Conditions

Table 3 Loading & Boundary Condition

Speed (RPM)	HUB Load N	% Use	Water Pump Temperature	Fit Conditions	Housing diameter	Sleeve OD	Radial Clearance(Ball)	Radial Clearance (Roller)
1800	600	19.7	-30	Max. Interference condition	Max Interference condition		Minimum Clearance	
					29.90	30	.02	.02

**Thermal Condition**

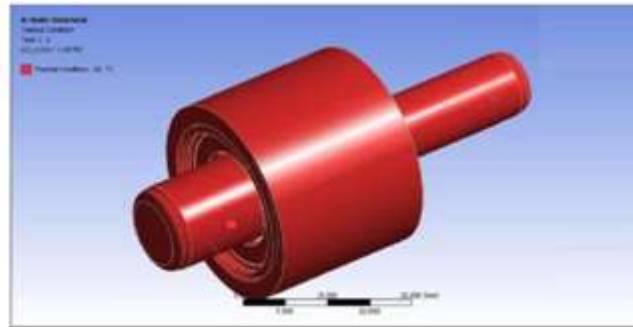

Fig. 3.5

**Solution**

After running the solution of above model we get different values of solutions such as, Maximum principle stress, Equivalent Stress, Total deformation and equivalent strain. All the results are described below

Equivalent Stress: 399.08 Mpa (max)

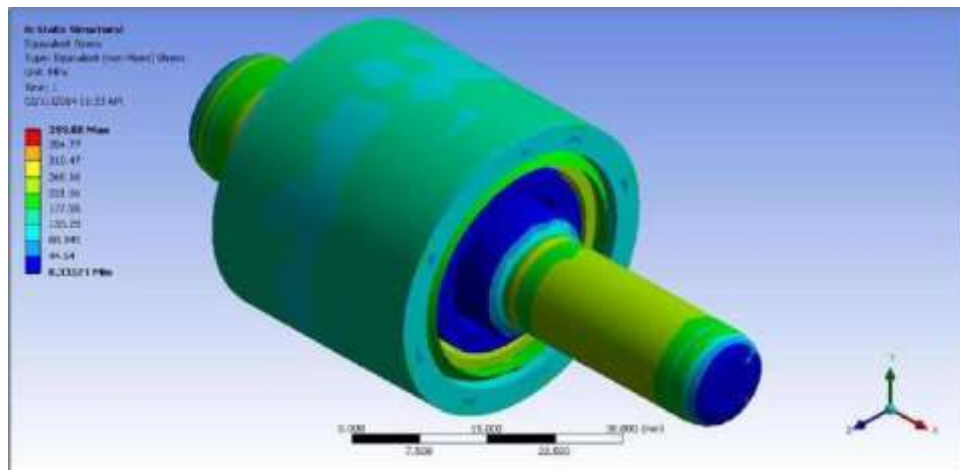
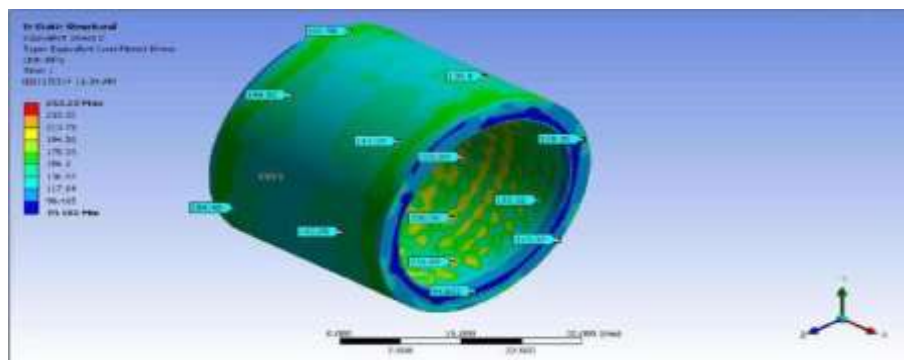

fig 3.6 Equivalent Stress Plot

Equivalent Stress for housing: Max Stress 252.25 < 310 Mpa (Allowable stress)



Equivalent Stress for housing: Max Stress 252.25 < 310 Mpa (Allowable stress)

Total Deformations for housing: 0.001194 mm (Max)

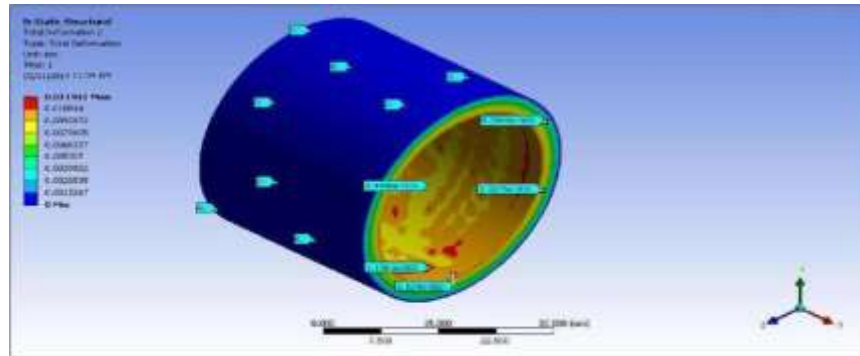

Fig. 3.8 Total Deformation for housing

Equivalent Stress for Shaft: Max Stress 399.08 < 460 Mpa (Allowable stress)

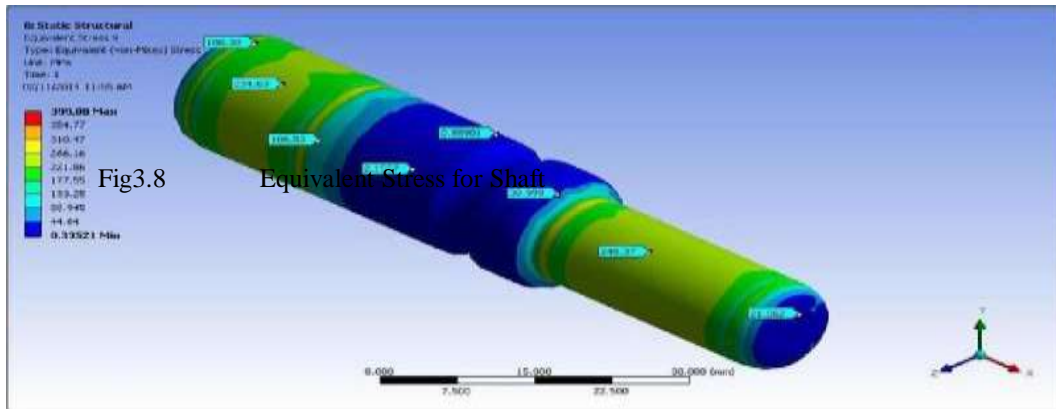

Fig3.8 Equivalent Stress for Shaft

Directional Deformations for Shaft (Y-axis): Max. Deformation 0.00335 mm

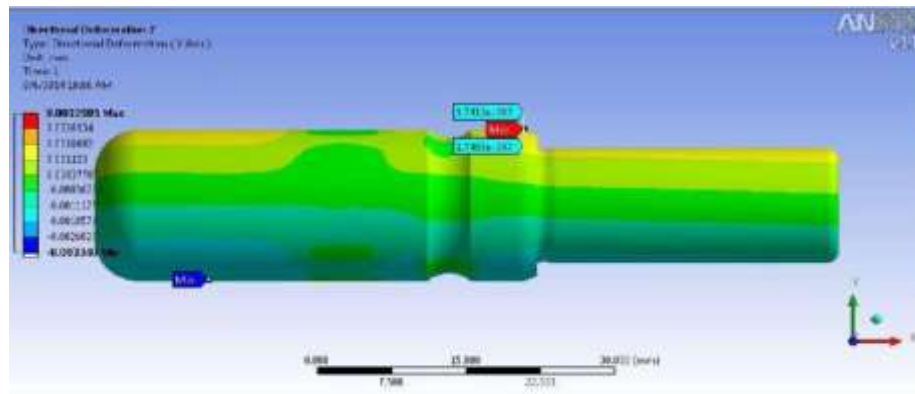

Fig 3.9 Deformation of Shaft in Y- direction

Equivalent Stress for Rollers: Max Stress 47.757 < 460 Mpa (Allowable stress)

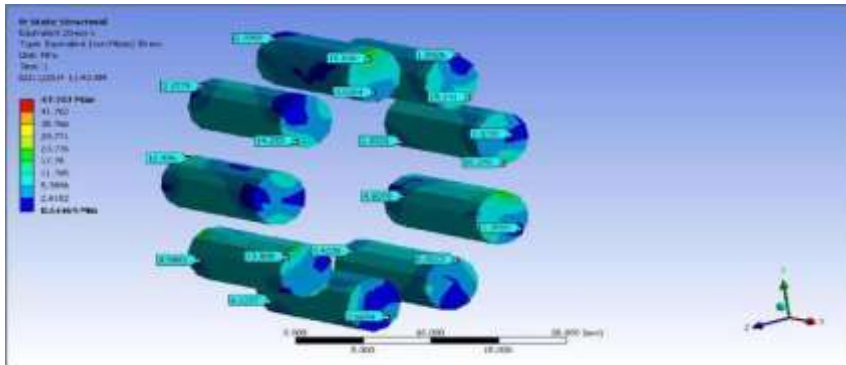

Fig 4.0 Equivalent Stress for Rollers

Directional Deformations for Rollers (Y-axis): Max. Deformation 0.003086 mm

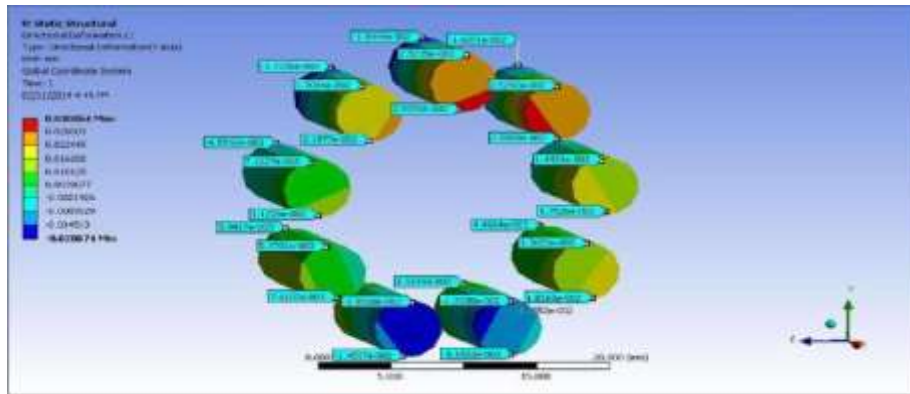

Fig 4.1 Deformation Plot For Rollers (Y – Direction)

Equivalent Stress for Balls: Max Stress 29.274 < 460 Mpa (Allowable stress)

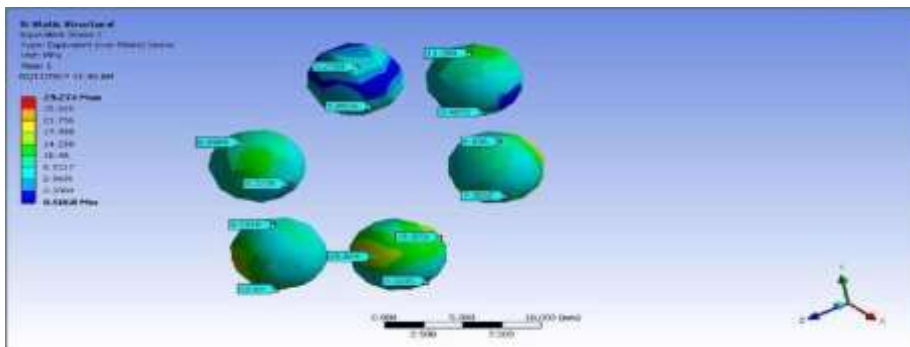

Fig 4.3 Equivalent Stress For Ball

Directional Deformations for Ball (Y-axis): Max. Deformation 0.00939 mm

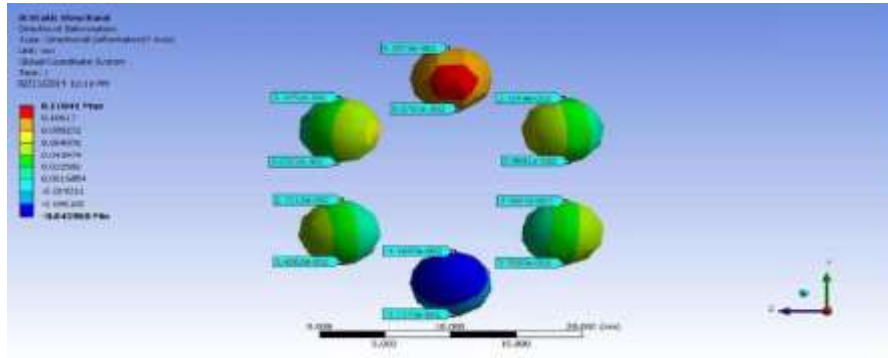

Fig4.4 Directional Deformations for Ball (Y-axis)

Equivalent Stress for Sleeve: Max Stress 329 < 460 Mpa (Allowable stress)

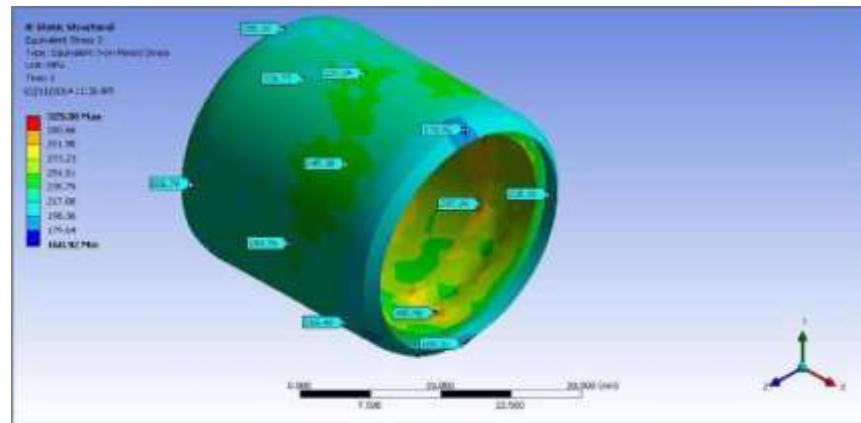

Fig 4.5 Equivalent Stress for Sleeve

Equivalent Stresses at inner area of sleeve

#### IV. ANALYTICAL CALCULATIONS

##### Life of Bearings

The life of the bearing decreases with an increase in the load.

$$\frac{L_d}{L_e} = \left(\frac{C_d}{P_d}\right)^k$$

k = 3 for ball bearings

=10/3 for roller bearing

L<sub>d</sub> = desired life

L<sub>c</sub> = life from the table (manufacturers catalog)

C<sub>d</sub> = dynamic rating from manufacturer

P<sub>d</sub> = design load





The equations can be rewritten as depending upon the variable to be calculated

$$C_d = P_d \left( \frac{L_d}{L_e} \right)^{1/2} \quad L_d = L_e \left( \frac{C_d}{P_d} \right)^k$$

#### Equivalent Combined Radial Load For combined radial and thrustloads

$$P = V X R + Y F_t$$

P = equivalent radial load

R = actual radial load

F<sub>t</sub> = actual thrust load

X = radial factor (usually 0.56)

V = 1.0 for inner race rotating

= 1.2 for outer race rotating

#### Given Data:

Dynamic Rating from Manufacturer: 13500 N

Radial Load Fr = 650 N

Axial Load Fa = 190 N

Radial Factor = 0.56

There for, equivalent radial load, P = 0.56\*1.2\*650+2\*190

$$P = 816.8 \text{ N}$$

#### Life of Bearing

$$L_{10} = \left( \frac{C}{P} \right)^3$$

$$= \left[ \frac{13500}{737.152} \right]^3$$

$$L_{10} = 4514.96 \text{ million rev.}$$

#### Bearing Life in Hours L10h

$$L_{10h} = L_{10} * 10^6 / 60 n$$

Where n = Integral Shaft Speed= 1500rpm

$$L_{10h} = 53176.195 \text{ hrs.}$$

## V. DISCUSSION AND COMPARISON OF RESULTS

Now we have to compare the results of Geometry after deformation. For the comparison purpose we have calculated stresses, deformation, and most important life of Bearing.

#### Bearing Clearances Effects

Clearance between rolling element like rollers/ balls and sleeve is most critical area of Integral Shaft bearing. Friction occurs between rolling element and sleeve there is chances of failure of bearing. As per

bearing design clearance is 0.02 mm we have to compare this clearance after thermal expansion of bearing components.

**At Ball side Clearance ( All dimensions are in mm)**

Before and after thermal expansion effect on dimensions of Shaft, Ball and Sleeve given in Table 4.

**Table 4 dimensions comparison after deformation at ball side**

Component	Diameters	Deformation	diameter after deformation
Shaft	14.225	0.004086	14.229086
Balls	6.35	0.00935	6.35935
Sleeve	26.925	0.00315	26.92815

Clearance between ball and sleeve after deformation:  $26.92815 - [14.229086 + (6.35935 * 2)]$

Clearance = 0.019363 mm < 0.2 mm

## VI. REFERENCES

- [1] Ambeprasad.S.Kushwaha, Atul B Wankhade, Dinesh E Mahajan, Darshan K Thakur, "Analysis of the Ball considering the Thermal (Temperature) and Friction Effects", National Conference on Emerging Trends in Engineering & Technology (VNCET-30 March'12).
- [2] Brian P. Graney & Ken Starry, "Rolling Element Bearing Analysis", from material Evaluation vol 70, pg 78-85, jan 2012
- [3] Huei, L (2011). Finite element simulations with Ansys workbench 13 theory – application- case study.
- [4] JafarTakabi& M.M. Khonsari, "Experimental testing and thermal analysis of ball bearings", Department of Mechanical Engineering, 2508 Patrick Taylor Hall, Louisiana State University, Baton Rouge, LA 70803, United States, 19 October 2012.
- [5] Jun sun, GuiChanglin, " Hydrodynamic lubrication analysis of journal bearing considering misalignment caused by shaft deformation," School of Mechanical and Automotive Engineering, Hefei University of Technology, May 2008.
- [6] Laniado-Jacome Edwin," Numerical Model to Study of Contact Force in A Cylindrical Roller Bearing with Technical Mechanical Event Simulation", Mechanical Engineering department, carlos III University , Madrid, 28911, spain, March 2011.
- [7] PrasannaSubbaraoBhamidipati, " FEA Analysis of Novel Design of Cylindrical Roller Bearing," mater thesis submitted in R.C.E, Affiliated to Jawaharlal Nehru technological university Hyderabad, India may, 2009.
- [8] Pang Chunjun, "Static Analysis of Rolling Bearing Using Finite Element Method", Master thesis submitted in University of Stuttgart May 2009.
- [9] S.J. Lacey, An overview of bearing vibration analysis, Maintenance and asset management , 23(6)2009 32-42.
- [10] Takeo Koyama,"applying FEM to design of Automotive Bearing," Automotive Bearing Technology Department, NSK-2009.
- [11] T.A. Harris, M.N Kozzalas, Rolling Bearing Analysis (5<sup>th</sup>Edition ), China Machine Press, 2013.

## CITE AN ARTICLE

Pal, Vimal Kumar, and Prabhat Kumar Sinha, Dr. "STRUCTURE AND THERMAL ANALYSIS OF INTEGRAL SHAFT BEARING USING ANSYSBENCHWORKS 14.0." *INTERNATIONAL JOURNAL OF ENGINEERING SCIENCES & RESEARCH TECHNOLOGY* 6.7 (2017): 877-86. Web. 25 July 2017.